



**Pool Vac XL® Navigator Pro®**  
**Pool Vac Classic™**  
**Owner's Manual**



Hayward Pool Products  
620 Division Street Elizabeth, NJ 07207  
Phone (908) 351-5400  
[www.hayward-pool.com](http://www.hayward-pool.com)

P/N K540AD-Rev E



# Turbine Suction Cleaner

## OWNER'S MANUAL

Congratulations on your purchase of your Hayward automatic suction pool cleaning system from Hayward. Your Cleaner is the smart, efficient way to clean your in-ground pool. Hayward Turbine Cleaners are powered by your pool's filter system and are designed to work well with most systems. Therefore the performance of the Cleaner in your pool will be relative to that power source. Because the operation and performance of the Cleaner are system reliant, there is a remote possibility that a "service call" may be necessary to complete the proper installation of your Cleaner. Because this is an installation related call, it will be at the consumer's expense. Also, one or more of the accessories designed for the Cleaner, including additional hose sections (if needed), might be applicable to your installation. Consult your Hayward dealer for the price and availability. For Technical Assistance, call Hayward at 908-355-7995 (USA only).

### For Your Records

Record the following information for your convenience

- 1) Purchase Date \_\_\_\_\_
- 2) Serial Number \_\_\_\_\_

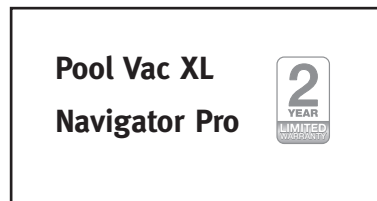

### Note

Hayward Turbine Cleaners should not be used to clean the pool for spring start-up unless the conditions noted in Step 1 are met. On those occasions, where your pool is subjected to an abnormal debris load, maintenance steps should be taken to return the pool to "pre-installations" condition.



# Installation

## INSTALLING YOUR HAYWARD CLEANER IS SIMPLE...

To prepare your pool for installation, please follow the easy steps listed below. After reading these instructions, the “How To” installation DVD (included with Pool Vac XL & Navigator Pro only) will walk you through the installation step-by-step, and it will also give you some maintenance and trouble-shooting hints. These instructions apply to all Hayward Turbine Cleaner models.

### Step 1

Check the pool and remove any large objects that might interfere with the cleaner’s operation. **Check to see that the water level is at the recommended level.** Check the water chemistry. Make sure that the water is properly balanced and that the pool is free from algae. **Algae can adversely affect the operation of the Cleaner and its performance.**

### Step 2

Clean or backwash the filter, and clean the hair and lint prior to installing the Cleaner. Following the installation of your Cleaner, clean the system at regular intervals according to individual pool conditions.

### Step 3

There are connector hoses (9 with PV XL & NAV PRO, 7 with PV Classic) and one leader hose with a hose cuff are included. The hose cuff has a red sticker attached to it that reads “REMOVE LABEL AND CONNECT TO CLEANER”.

Connect the exclusive Hayward hose sections together by pushing and twisting the tapered male connector end of each hose firmly into the open female end of the adjacent hose (see *Figure 1*). Depending on the size and shape of your pool, all hose sections might not be used. However, the leader hose must be used or your Cleaner will not operate properly. It is not necessary to “Bottom Out” the connections, but they **must** be tight enough to prevent any air leaks. Wetting the hose ends will make it easier to connect the hose sections.

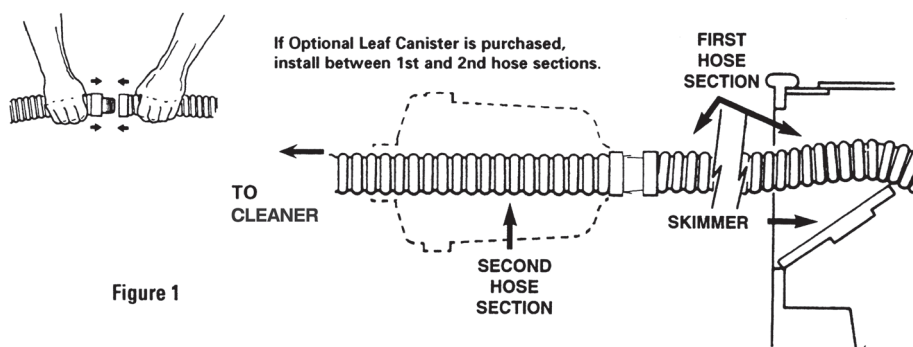

Figure 1



# Installation

## INSTALLING YOUR HAYWARD CLEANER IS SIMPLE...

### Step 4

The hose should reach from the skimmer or Hayward Vac Lock® to the furthest point in the pool, **plus two (2) extra hose sections**. (The length of each hose section is four feet.) **This extra length is absolutely necessary for proper operation of your Hayward Cleaner.** If the hose is not long enough, it will be necessary to purchase additional hose sections from your Hayward dealer. The hose length supplied has been determined to be sufficient for the class and size of pools for which each type of cleaner is sold – 40 feet for PV XL & NAV Pro, 32 feet for PV Classic. If your hose requirement is more than this, you must obtain additional hose sections for your cleaner to work properly. After the correct hose length has been assembled, fill hose completely with water. Insert Flow Gauge into the leader hose, then attach the C-Clip of the gauge onto the first hose section. Make sure the Flow Gauge is under water. (see Figure 2)

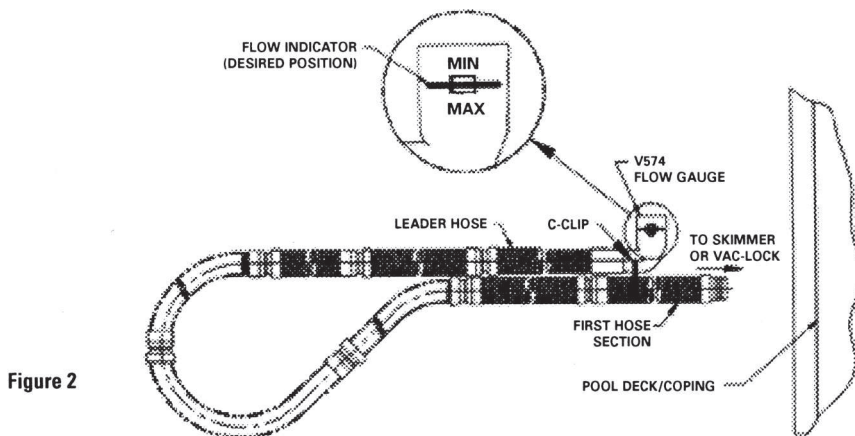

Figure 2

### Step 5

Turn the filter system on and allow it to run long enough to eliminate any air in the system. Connect the V093C Skimmer Cone adapter to the tapered male end of the vacuum hose if you are connecting the hose to your skimmer. Then, insert the cone into the suction port of the skimmer (see Figure 3) or, **if you are using a Hayward Vac Lock, insert the hose end directly into the Vac Lock without using the cone.** (Refer to **Important Tips** for more specific skimmer information.)

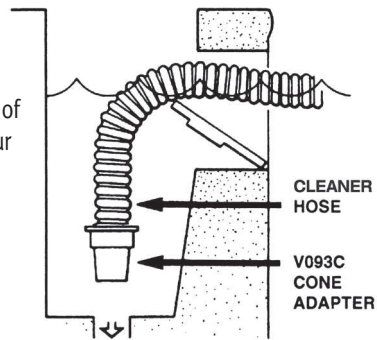

Figure 3



# Installation

## INSTALLING YOUR HAYWARD CLEANER IS SIMPLE...

### Step 6

Check the water flow reading on the Flow Gauge. (Refer to Step 4, Figure 2). The black disk should be in the box between the “MIN” and “MAX” markings. If the setting is higher than required with the black disk outside of the box on the “MAX” side and you have connected your hose to the skimmer, it will be necessary to reduce the vacuum/water flow by using a valve or valves in the filter system, or the Hayward V094 Regulator Valve or an optional Hayward Automatic Skimmer Vacuum Plate designed to adjust vacuum/water flow. To install the V094 Regulator Valve, turn the filter system off, remove the hose from the V093C Skimmer Cone, and after closing the Regulator Valve (Rotate the blue collar clockwise until tight), insert the Valve into the Skimmer Cone, and insert the hose end into the Valve (see Figure 4).

Turn the filter system on and allow it to run long enough to eliminate any air in the system. Turn the blue collar counter clockwise until proper reading appears on the gauge. If a Hayward Skimmer Vacuum Plate is to be used, follow the installation instructions included with the Skimmer Vacuum Plate.

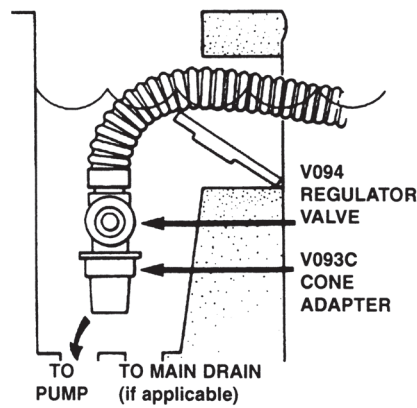

Figure 4



# Installation

**INSTALLING YOUR HAYWARD CLEANER IS SIMPLE...**

## Note

The V094 Regulator Valve and the Hayward Skimmer Vacuum Plate can only be used to LOWER an initial vacuum reading that is TOO HIGH. **The Regulator Valve and the Skimmer Vacuum Plate cannot be used to INCREASE the initial vacuum reading.** An initial reading that is too low to meet the water flow setting necessary to operate the cleaner is indicative of a system problem, and not a problem with the cleaner.

Contact your Authorized Hayward Dealer for assistance.

If you have connected your hose to the Hayward Vac Lock, it will be necessary to adjust the vacuum/water flow using the 3-way valve at the filter system. The handle on the valve should be turned so that the Flow Gauge which is installed in the Cleaner hose reads properly (*refer to Figure 2*). After the 3-way valve has been properly adjusted, **the 3-way valve should be marked so that the water flow can be adjusted by referring to the valve handle mark**, rather than reinstalling the Flow Gauge in the hose each time an adjustment is necessary.

### Step 7

Remove the Flow Gauge from the hose and keep it handy. You will want to use the Flow Gauge to check the Cleaner's operation from time to time if the Cleaner is connected to your skimmer. If you are using a Hayward Vac Lock, the Flow Gauge will only be necessary if you neglect to mark the valve gauge, or if replacement of the valve gauge is necessary.

### Step 8

Check the rear flap adjuster dial at the left rear of the Cleaner. It should be set at position number II which is the middle position (*see Figure 5*). Submerge the Cleaner into the water to remove all of the entrapped air. When escaping air bubbles cease, you are ready to connect the hose.

Connect the hose cuff of the leader hose to the Cleaner and submerge the hose to remove all air as when vacuuming the pool with a standard hand-vacuum (*see Figure 6*).

**Do not use the return line/inlet water to "sink" the Cleaner hose, as this will force air into the cleaner head, and possibly cause performance problems.**



# Installation

INSTALLING YOUR HAYWARD CLEANER IS SIMPLE...

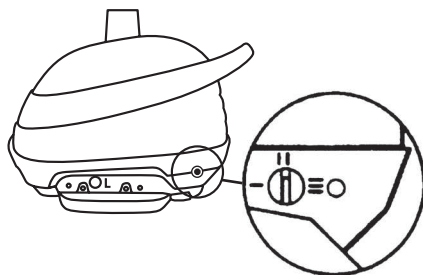

Figure 5

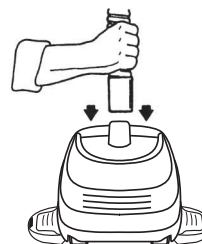

Figure 6

### Step 9

Observe your Cleaner in operation, and make sure that the return line flow is not affecting the Cleaner's programmed steering and preventing the Cleaner from covering the entire pool. If the cleaner hose is being pushed across the surface of the pool, it will be necessary to redirect the return line water flow downward. This is to allow the Cleaner to move its programmed cleaning pattern.

### Step 10

Observing the Cleaner in operation, it should move about the pool without spending an excessive amount of time against the steps or other obstructions (vertical walls, ladders, etc.) If the Cleaner seems to get "hung up," turn the rear flap adjuster to position I (see Figure 5).

### Step 11

Your Cleaner will climb the vertical walls in concrete and fiberglass swimming pools if there is at least a seven inch (7") radius where the walls and floor meet. The Cleaner's wall climbing is governed by the programmed steering and therefore it will not climb the wall each time it comes in contact with a wall. When the Cleaner does start up a wall, it will not always go all the way up the wall. If the Cleaner does not seem to be "sticking" to the wall, turn the rear flap adjuster to position III (see Figure 5). If the Cleaner climbs to the water's surface and sucks air, turn the rear flap adjuster to **Position I** (see Figure 5). If the cleaner continues to climb too high, reduce the water flow until proper operation is achieved.

Approximately ninety percent (90%) of the dirt in a concrete pool will be on the floor of the pool. Approximately ten percent (10%) of the dirt will be on the walls. Your Cleaner will spend its cleaning time accordingly.



# Turbine Suction Cleaners

## IMPORTANT TIPS

### Pool Vac XL/Navigator Pro

In one piece fiberglass pools there is very little dirt on the walls, but your Cleaner will still climb the walls. Due to the shape (severe angles) of most in-ground vinyl liner pools, your Cleaner's cleaning is confined to the bottom (both shallow and deep) and the hopper sides. Hayward Turbine Cleaners do not climb the vertical walls of in-ground or on-ground vinyl liner pools. However, normal dirt and debris do not adhere to these walls.

### DO NOT COIL HOSE

When storing your cleaner the hose sections must be stored straight, not coiled. A coiled hose will create a memory in the hose that will impede the Cleaner's ability to move properly in your pool. **Coiled hoses are not covered under the Hayward warranty.** When removing the Cleaner from your pool, be sure to grasp the cleaner by its handle, not by its hose, otherwise the Cleaner might be damaged should the hose disconnect from the cleaner.



1. Skimmers come in many configurations and cannot all be described here. Three basic types are discussed however.

Some skimmers have two (2) holes in the bottom. There might be a valve, float or cover over the holes. Remove everything in the skimmer, exposing the holes. The rear hole is usually the suction port. In some cases it will be necessary to use the V094 Regulator Valve to control water flow through the Cleaner (*see Figure 4*).

Some skimmers have only one hole in the bottom. This suction port is usually controlled by a valve at the filter system and most likely will not need a V094 Regulator Valve (*see Figure 3*).



## Turbine Suction Cleaners

### IMPORTANT TIPS

Some skimmers have a vari-flow or diverter valve in the bottom of the skimmer. This valve can be turned to regulate skimming and main drain suction. Turn the valve to full skim and then adjust the Flow Gauge by turning the valve toward main drain suction. Usually this valve is the same size as the Cleaner's hose end, and it will therefore be necessary to purchase a V098 Hose Adapter (*see Figure 7*). After the proper gauge reading has been established, the diverter valve will have to be locked in the place with a wedge of some kind so that it won't change position with operation of the Cleaner.

2. Periodically check the water flow/vacuum to be sure that your Cleaner is operating as efficiently as possible. **Remember, too much vacuum is just as bad as too little.**
3. Periodically check to make sure that the Cleaner hose is securely attached to its suction source (i.e. Skimmer, Skimmer Vac Plate Vac Lock, etc.)
4. Disconnect the Cleaner hose from the skimmer/regulator valve, or, if using a "dedicated line", turn cleaner valve off prior to "backwashing", so as not to restrict water flow.
5. Never coil the Cleaner hose. **Coiled hose is not covered under the warranty.**
6. When the Cleaner is out of the pool, always disconnect the leader hose from the Cleaner's head.
7. Always carry your Cleaner by the molded-in handle. **Do not carry it by the hose.**
8. When swimming in the pool, remove your Cleaner from the water.
9. If you are going to super chlorinate, shock, or add gas chlorine to your pool, make sure the cleaner and its hose are removed prior to doing so.

Figure 7

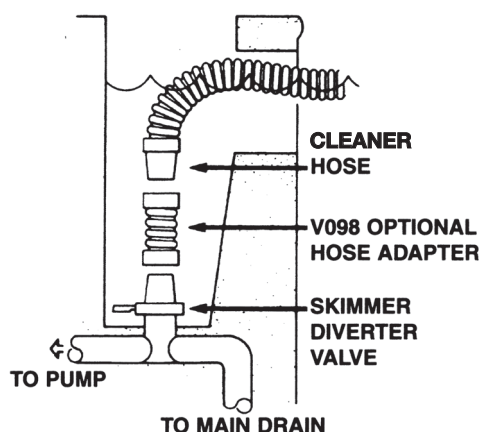



# Turbine Suction Cleaner

## MAINTENANCE TIPS

1. **Check the condition of the “shoes, wings and flaps” periodically.** The shoes and wings have wear indicators on their sides and should be checked occasionally to determine if they need replacing. The shoe wear indicator is a line on the side of the shoe that appears as a difference in texture. When this texture difference is no longer visible at the bottom of the shoe when viewed from either side, the shoes must be changed (see Figure 8). Also on the side, the wing wear indicator is a horizontal line which has three (3) vertical lines above it. When you can no longer see the horizontal line, the wings must be changed (see Figure 9). The Hayward Tune-Up Kit is available from your dealer. Shoes, wings and flaps may also be purchased separately.

### 2. SHOE REPLACEMENT:

- Turn unit upside down.
- Insert screwdriver between foot and shoe on one of the pads (see Figure 8).
- Using a lifting motion, remove the shoe from the foot.
- Dip a new shoe in water and attach the shoe to the foot, making sure to put the small post into the small hole and the large post into the large hole. These posts and holes are different sizes to prevent the shoes from being improperly installed.
- Repeat Steps b,c, and d for each shoe.

Figure 8

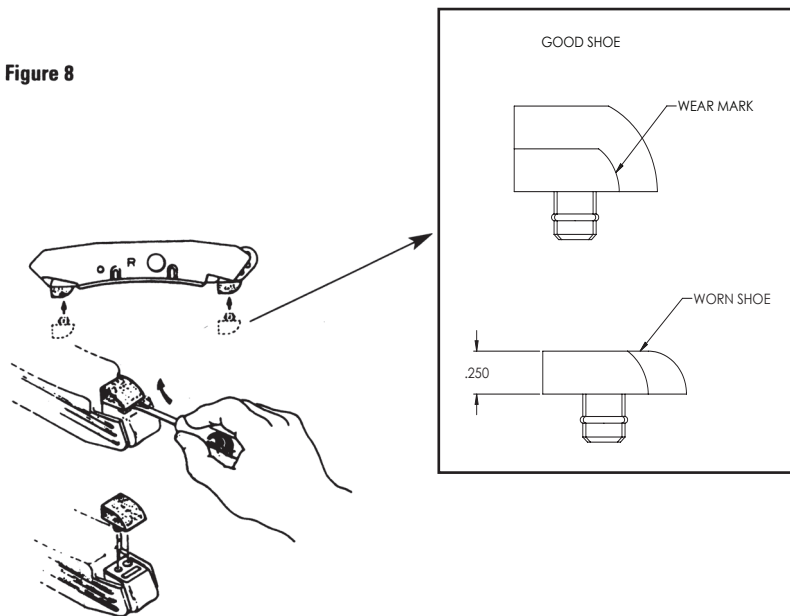



# Turbine Suction Cleaner

## MAINTENANCE TIPS

### 3. WING REPLACEMENT:

- a) Using a screwdriver, remove the plugs from both pods (see Figure 9).
- b) Remove the old wings by bending the wings up toward the sides of the cleaner, and lift them off their hooks (see Figure 10). If any of the wing hooks are broken, take the Cleaner to your dealer for pod replacement as the unit will not function properly if the wings are not properly attached.
- c) Replace the wings, making sure that you match the “L” (Left) and “R” (Right) of the pods.
- d) Replace the pod plugs and tap them into place with the screwdriver handle.

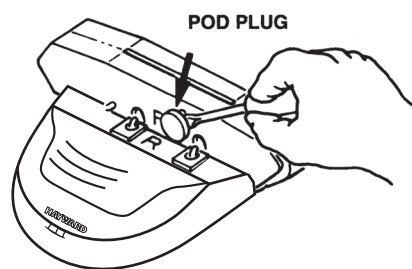

Figure 9

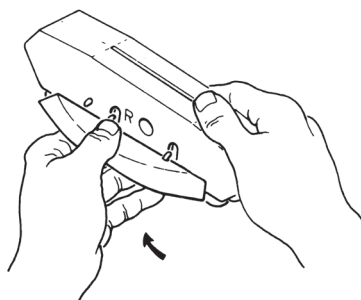

Figure 10

## Turbine Suction Cleaner

### MAINTENANCE TIPS

#### 4. FLAP REPLACEMENT:

- a) Remove the front and rear flaps from your Cleaner by inserting a small screwdriver between the flap and the lower body near the pivot point of the flaps (see Figure 11).

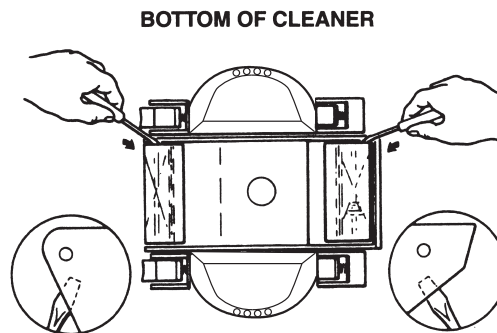

Figure 11

- b) You will notice that your replacement flaps look similar but are marked “Front” and “Rear” on the flap. **Because the springs in the flaps are different, it is absolutely necessary to install the proper flap in the front and rear of the unit.** Failure to do so will result in unsatisfactory performance of your Cleaner. When installing the front flap, be sure that the extended leg of the spring is inserted into the notch on the front of the lower body (see Figure 12). Push the flap in place. You will actually feel and hear a snap when the flap is in place. Fold the flap in towards the bottom of the Cleaner. You will feel some resistance at this point (that is normal). As the flap snaps into its normal position, you will feel the spring action and notice that the front flap is now in its normal operating position.

When installing the rear flap, the extended leg of the spring must fit against one of the flat surfaces of the cam (see Figure 12).

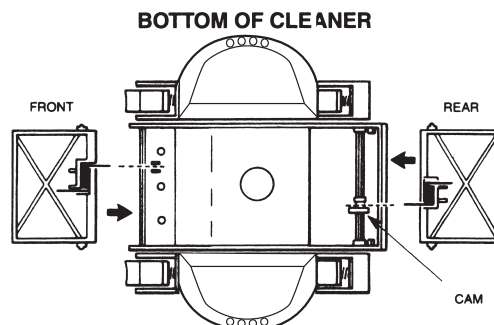

Figure 12



# Removal Instructions

## “EASY OPENING BOTTOM”

### 6. “EASY OPENING BOTTOM”

The purpose of the “EASY OPENING BOTTOM” is to allow quick access to the turbine/vacuum chamber for easy cleaning and maintenance.

Should the Cleaner stop moving or become sluggish due to debris trapped in the throat or inside the unit, the turbine/vacuum chamber is accessible following the instructions on pages 13 & 14 of this manual.

1. Turn off pump.
2. Remove Cleaner from pool.
3. Disconnect Cleaner from leader hose.
4. Turn Cleaner upside down.
5. Locate and loosen the captive screw behind the throat in the center of the bottom (see Figures 14 and 15).

Figure 14 - Concrete Cleaner

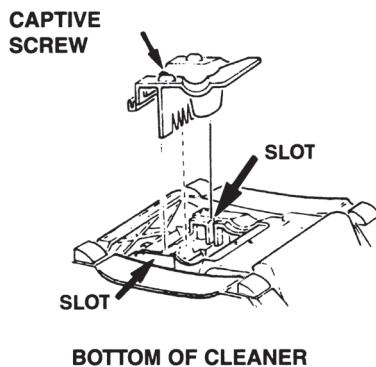
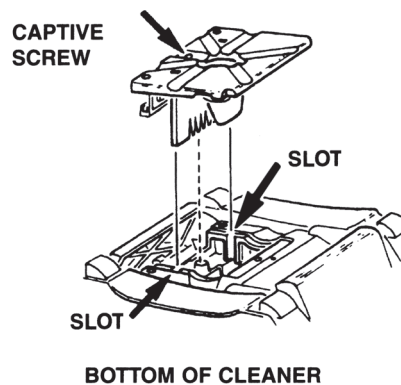

Figure 15 - Vinyl Cleaner





## Removal Instructions

### "EASY OPENING BOTTOM"

6. Lift "Easy Opening Bottom" (see Figures 14 & 15).
7. Clean turbine/vacuum chamber (see Figure 16).
8. Check turbine for free movement.
9. Reinstall "Easy Opening Bottom" by lining up the cover screen with the two slots shown in Figures 14 and 15. Then slide the cover in place and tighten the captive screw.
10. Reinstall your Cleaner in the pool per installation instructions.

Figure 16

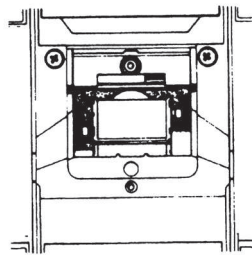

TURBINE/VACUUM CHAMBER



# Turbine Suction Cleaner

## TROUBLESHOOTING GUIDE

---

**Problem: Slow/no forward movement**

---

CAUSES	SOLUTIONS
Lack of/improper water flow through cleaner	Check water flow with Flow Gauge and adjust as per Step 6.
Blockage of the Cleaner throat	Clear blockage
Worn shoes	Replace shoes
Worn wings	Replace wings
Improper cleaner model for application	Call 908-355-7995 (U.S.A. only)

---

**Problem: Cleaner fails to climb vertical walls gunite/concrete pool**

---

CAUSES	SOLUTIONS
Improper shoes for application	Call 908-355-7995 (U.S.A. only)
Lack of/improper water flow through cleaner	Check water flow with Flow Gauge and adjust as per Step 6.
Blockage of the Cleaner throat	Clear blockage
Worn shoes	Replace shoes
Worn wings	Replace wings
Hose too short	Install additional hose sections per installation instructions.
Improper tension on rear flap	Turn rear flap adjuster to III



# Turbine Suction Cleaner

## TROUBLESHOOTING GUIDE

---

**Problem: Cleaner climbs to water surface and sucks air.**

---

CAUSES	SOLUTIONS
Too much/improper water flow through cleaner	Check water flow with Flow Gauge and adjust per instructions in Step 6
Improper tension on rear flap	Turn rear flap adjuster to position 1 If still climbing too much, reduce water flow until proper operation is achieved
Steering failure	1) Check and clean rear screen  2) Check to see that cone gear is free and rotates smoothly in both directions  3) Check medium turbine and spindle gear assemblies for malfunction

---

**Problem: Cleaner head “floats”**

---

CAUSES	SOLUTIONS
Cleaner head is HEAVIER than WATER, and should not “float”	Remove all air from cleaner head Stop all air from entering the pool through the return lines If cleaner head and hose are covered with fine bubbles, give the hose a good tug. This will release the air bubbles and allow the cleaner head to settle to the bottom of the pool until the hose is covered with bubbles again
The cleaner head is actually being pulled or lifted off the bottom of the pool by the cleaner hose, or return line flow – either at the surface or at the bottom of the pool – or both	Readjust return outlets to prevent water flow interfering with cleaner head and/or hose



# Turbine Suction Cleaner

## TROUBLESHOOTING GUIDE

---

**Problem: Cleaner sticks at steps, corners, etc.**

---

CAUSES	SOLUTIONS
Improper water flow	Check water flow with Flow Gauge and adjust as per Step 6.
Worn shoes	Replace shoes
Worn wings	Replace wings
Hose too short	Install additional hose per installation instructions.
Steering failure	<ol style="list-style-type: none"><li>1) Check and clean rear screen</li><li>2) Check to see that cone gear is free and rotates smoothly in both directions</li><li>3) Check steering program and troubleshoot - then:<ol style="list-style-type: none"><li>a) clean, repair or replace gearbox</li><li>b) check pod/A-frame connection and REPLACE IF NECESSARY. DO NOT ATTEMPT TO RETIGHTEN LOOSE PODS.</li><li>c) check medium turbine and spindle gear assemblies</li></ol></li></ol>



## Turbine Suction Cleaner

---

### DISCLAIMER

---

- A) Pool plaster is affected by age, water, chemistry, etc.
- B) Pool plaster can deteriorate over a period of time.
- C) The integrity of “good” pool plaster is such that a pool vacuum cleaner - automatic or manual cannot remove that plaster.
- D) The integrity of “good” pool plaster is such that the plaster will cause wear on the Cleaner - not vice versa.
- E) Vinyl is affected by age, sunlight and water chemistry.
- F) Vinyl can become brittle and weak.
- G) Vinyl can also be affected by the installation and the pool’s surroundings.
- H) When installing your Cleaner, you must assume all responsibility for the condition of the pool and the pool’s surroundings.

---

**To better serve you, please have the following information available if you call Hayward’s Technical Service Department at 908-355-7995 (U.S.A. only):**

- 1) The Purchase Date of your Hayward Turbine Suction Cleaner.
  - 2) The Serial Number of your Hayward Turbine Suction Cleaner.
  - 3) The number of the Hose Sections used.
  - 4) A current water flow indicator setting (*refer to Step 6, Figure 2*).
-





# Turbine Suction Cleaner

## WARRANTY REGISTRATION

### HAYWARD POOL PRODUCTS, INC. LIMITED PARTS WARRANTY

To the Original Retail Consumer/Purchaser (the "PURCHASER") of the Hayward Pool Vac XL, Navigator Pro and Pool Vac Classic (the "CLEANER"):

Hayward Pool Products, Inc. ("HAYWARD") warrants the cleaner from the date of original purchase. The Limited Warranty is as follows:

**\* Important: Retain your Bill of Sale for Warranty Eligibility**

- Year 1)** All components of the CLEANER (including hoses, internal motion devices and external motion devices) are warranted to be free from defects in workmanship and materials for a period of one year from the original date of purchase.
- Year 2)** All Pool Vac XL and Navigator Pro components of the CLEANER other than external motion devices are warranted to be free from defects in workmanship and materials for a period of two years from the date of original purchase. External motion devices are comprised of the shoes (located on the bottom of the unit), wings (located on the sides of the unit) and flaps (located on the front and rear of the unit).

SHOULD THE CLEANER FAIL TO BE IN GOOD WORKING ORDER IN ACCORDANCE WITH THE ABOVE SCHEDULE, HAYWARD WILL AT IT'S OPTION REPAIR OR REPLACE THE CLEANER OR ANY DEFECTIVE PARTS AT NO ADDITIONAL CHARGE EXCEPT AS SET FORTH BELOW. REPAIR PARTS AND REPLACEMENT PRODUCTS WILL BE FURNISHED ON AN EXCHANGE BASIS AND WILL BE NEW OR FUNCTIONALLY EQUIVALENT. ALL PARTS REMOVED AS A RESULT OF REPLACEMENT SHALL BECOME THE PROPERTY OF HAYWARD. LIABILITY OF HAYWARD AND THE SOLE REMEDY OF THE PURCHASER WHETHER IN CONTRACT UNDER ANY WARRANTY, IN TORT (INCLUDING NEGLIGENCE), IN STRICT LIABILITY OR OTHERWISE, SHALL BE LIMITED TO THE REPAIR OR REPLACEMENT OF DEFECTIVE PARTS ONLY AND SHALL IN NO EVENT EXCEED RETURN OF THE AMOUNT OF THE PURCHASE PRICE PAID BY THE PURCHASER.

This Limited Warranty is subject to the following terms and conditions:

- 1) This Limited Warranty shall not apply to damage caused by failure to perform normal maintenance on the CLEANER (e.g. monitoring flow/suction and replacing worn shoes, wings and flaps).
- 2) This Limited Warranty shall be void if the CLEANER is modified in any respect, including, but not limited to the use of any parts other than genuine HAYWARD parts.
- 3) This Limited Warranty shall not apply to any injury, loss, damage, defect or malfunction of the CLEANER or failure of the CLEANER to function resulting from any failure to operate or maintain the CLEANER in accordance with the directions contained in the Installation Manual or operating instructions provided by HAYWARD or any injury, loss, damage, defect, malfunction or failure to function resulting from any misuse, unreasonable use, tampering, abuse, accident, acts of God, alterations in the CLEANER by anyone other than HAYWARD including but not limited to such damages or injuries to parts resulting from improper installation or damage to pump parts resulting from running pump dry (e.g., interruption in or inadequate supply of water to internal pump parts due to loss of prime, or obstruction in lines, or



# Turbine Suction Cleaner

## WARRANTY REGISTRATION

- otherwise); or damage, defects, or malfunctions resulting from defects in, failure or malfunction of, or negligence, abuse, or misuse with respect to equipment other than the CLEANER.
- 4) This Limited Warranty shall not apply to the malfunction of, damage to, materials failure in, or changes in the appearance of the CLEANER resulting from exposure to sunlight or chemicals or chemical reaction to substances with which any part of the CLEANER may come in contact or parts which if worn, do not affect performance of the CLEANER.
  - 5) This Limited Warranty does not apply to cleaners used for commercial purposes.
  - 6) The CLEANER is designed to function in a properly designed, constructed and maintained pool. The limited warranty does not apply in the circumstances where the pool's design, construction or maintenance is defective, substandard or inappropriate for the CLEANER's operation.
  - 7) Deterioration, discoloration or brittleness of pool plaster and vinyl liners can be caused over time separately by, or in combination with, age and an imbalance in pool water chemistry, improper installation, and other factors. HAYWARD hereby disclaims any and all claims, and PURCHASER releases HAYWARD from any and all claims for damages to any pool plaster or vinyl liner in PURCHASER'S pool by reason of the use and/or operation of the CLEANER.
  - 8) This limited warranty is valid and enforceable only on CLEANERS assembled, manufactured, or purchased and installed in the United States of America and Canada.
  - 9) This limited warranty shall apply only to PURCHASER as original purchaser of the CLEANER from an authorized HAYWARD dealer and shall not apply to any subsequent purchaser, assignee or other recipient of the CLEANER from PURCHASER.
  - 10) This limited warranty does not apply unless the accompanying Registration Card is signed, completed and returned within the fourteen (14) days from the date of purchase. HAYWARD reserves the right to dispose of any Registration Card once it is received. PURCHASER must retain written proof of purchase.
  - 11) The foregoing limited warranty gives the PURCHASER specific legal rights which may vary from state to state, and accordingly, some of the listed conditions and exclusions may not apply to PURCHASERS living in certain states.
  - 12) Force Majeure  
Neither party will be liable to the other for any failure or delay in performance due in whole or in part to any cause beyond such party's reasonable control, including due to the elements, acts of God, acts of the other party, acts of civil or military authority, war, riots, or concerted labor action.
  - 13) Assignment, Modification  
The PURCHASER has no right to sell, transfer or assign any interest it has in this agreement without the prior written consent of HAYWARD.  
HAYWARD may, without notice, assign its interest in this agreement or any payment or other sum due hereunder without notice to or prior consent of the PURCHASER. If HAYWARD makes any such assignment, the assignee will have all of HAYWARD's rights, obligations, powers, privileges and remedies. Modification of this Agreement may only be made in writing signed by an authorized agent of HAYWARD.



## Turbine Suction Cleaner

### WARRANTY REGISTRATION

Should a defect in workmanship and/or materials in the CLEANER become evident during the term of the Limited Warranty, PURCHASER must ship the item freight prepaid to any authorized Factory Service Center as soon as possible after the discovery of the defect, together with a copy of the Bill of Sale including date of purchase and serial number of the item claimed to be defective, the name and address of the PURCHASER and a brief description of the problems/defects encountered. Call (888) 429-9273 for the name and address of the nearest Factory Service Center (outside the continental U.S. call (908) 355-7995). HAYWARD will at its option, repair or replace all defective CLEANER parts covered by this Limited Warranty at its own cost and expense and return same to consumer freight prepaid. HAYWARD is not responsible for any cost and expense of handling, packing, shipping, or transporting the CLEANER or any parts thereof to or from the service facility, unless expressly provided to the contrary by state law. No dealer, distributor or other similar person has any authority to make any warranties or representations concerning HAYWARD beyond the express terms contained herein. HAYWARD assumes no responsibility for any warranties beyond the express terms contained in this Limited Warranty. This Limited Warranty is in lieu of any other warranties expressed or implied, and is valid and enforceable only in the United States of America and Canada. The PURCHASER must provide written proof of the original date of purchase of the CLEANER in form reasonably acceptable to HAYWARD.

The exclusive forum for any dispute between the PURCHASER and HAYWARD will be binding arbitration, conducted in Union County, New Jersey under the rules of the American Arbitration Association, and the prevailing party will be entitled to an award of attorney's fees and costs.

THE FOREGOING WARRANTY AND REMEDIES ARE EXCLUSIVE AND ARE MADE EXPRESSLY IN LIEU OF ALL OTHER WARRANTIES, EXPRESS OR IMPLIED, WHETHER IN FACT OR BY OPERATION OF LAW, STATUTORY OR OTHERWISE, INCLUDING WARRANTIES OF MERCHANTABILITY AND FITNESS FOR USE OR A PARTICULAR PURPOSE. HAYWARD NEITHER ASSUMES NOR AUTHORIZES ANY OTHER PERSON TO ASSUME FOR IT ANY OTHER LIABILITY IN CONNECTION WITH THE SALE, INSTALLATION OR USE OF THE CLEANER AND HAYWARD MAKES NO WARRANTY WHATSOEVER FOR EQUIPMENT NOT SUPPLIED BY HAYWARD. THE FOREGOING WARRANTY DOES NOT COVER DAMAGE TO THE CLEANER RESULTING FROM ACCIDENT, MISUSE, ABUSE OR NON-HAYWARD MODIFICATIONS OF THE CLEANER. HAYWARD SHALL NOT BE LIABLE FOR DAMAGES DUE TO DELAYS IN DELIVERY OR USE. IN NO EVENT WILL HAYWARD BE LIABLE TO THE PURCHASER FOR ANY DAMAGES INCLUDING, BUT NOT LIMITED TO, ANY DIRECT, SPECIAL, INCIDENTAL OR CONSEQUENTIAL DAMAGES ARISING OUT OF OR RELATING TO THE SALE, INSTALLATION, OR USE OF OR INABILITY TO USE THE CLEANER, PURCHASER'S SWIMMING POOL OR FOR ANY CLAIM BY ANY OTHER PARTY.

